

Site Lighting

1. Services Rendered
 - a) Documentation
 - i) Contractor's representative shall deliver to the GCS a record of all services performed, and any deficiencies which require remedial action. No additional work outside the scope of this contract is to be performed without written authorization of the GCS or the The owner Group.
 - ii) Contractor shall record (in a manner consistent with THE OWNER's Work order/preventative maintenance system) detailed information ie. Fixture identification #, services performed and operational status. This information is to be given to the GCS.

2. Performance
 - a) Site Inspections
 - i) Frequency
 - a) Contractor shall perform these services on a monthly basis at 30 day intervals (± 3 days).
 - b) Normal Operations
 - i) Contractor shall activate all fixtures for the purpose of testing. Care should be taken as to activate circuits sequentially, to avoid a significant electrical demand spike. Proper operation of actuating devices such as photocells are also to be tested to ensure correct operation.
 - ii) Fixtures that are found to be non-operational are to be diagnosed and corrective action taken to return the fixture to a serviceable mode. Charges are to be in accordance with the compensation schedule, section 18. No additional work is to be completed without the authorization of the GCS or The Owner Group.
 - iii) Contractor shall affix a permanent label on the fixture indicating date of service. Additionally the contractor record what services were initiated along with fixture ID number on the work ticket. The information gathered shall be consistent with the preventative maintenance program to enable THE OWNER to make journal entries

3. Fees based on Appendix _____

- c) Diminished light output
 - i) Due to certain Lamp Life Cycle characteristics, fixtures may experience a noticeable reduction in light.
 - ii) When this condition occurs, contractor shall replace the lamp.
 - iii) Contractor shall label the fixture in such a manner as to clearly identify the date that the bulb and/or ballast replaced.

- d) Damaged equipment.
 - i) Any fixture found to have deficiencies are to be included in the monthly report. Contractor shall include cost of repairs if applicable.
 - ii) If continued operation of the fixture creates a safety issue or endangers the property, the fixture is to be taken out of service and the GCS notified immediately.

- e) Cleaning
 - i) All lenses are to be cleaned annually, utilizing manufacturers recommendations.
 - ii) Due to insect infestation or other conditions it may be necessary to clean the fixture more frequently. This additional work is included within the scope of this project.

- f) Normal Response
 - i) Response time
 - ii) Contractor shall respond to normal maintenance items within one business day when duly notified by the GCS
 - iii) Cost
 - iv) The cost to provide such service shall be in accordance with the attached schedule.

- g) Emergency Response
 - i) Response time
 - ii) When duly notified, Contractor shall respond for emergency services within four hours of notification.
 - iii) Cost
 - iv) The cost to provide such service shall be in accordance with the attached schedule.

- h) Rolling Stock
 - i) Contractor shall maintain an adequate supply of bulbs, ballasts photocells and ancillary materials to minimize return calls. In the event that the contractor does not have adequate stock on hand, THE OWNER shall not be charged subsequent call backs.

1. Irrigation Spec # 23 b "Quarterly Service Evaluations"

HOLOPHANE

**High Mast
Lowering Devices**

SECTION IV

MAINTENANCE INSTRUCTIONS

4.1 LUBRICATION

4.1.1 Winch The winch gear housing, as received from Holophane is lubricated and sealed. Additional lubrication is not required.

4.1.2 Aircraft Cable The winch cable and hoisting cables come from the manufacturer with a very light coating of lubricant. This lubricant is desirable and should not be removed. The winch cable should be checked for wear and corrosion and cleaned with a soft absorbent cloth and lubricated with a good quality acid free grease on a regular service interval. In normal atmospheres the cable should be serviced every two (2) years. If during inspection it is found that there are more than 12 broken wires in one lay of cord, the winch or, hoisting cables, replace with a new set of cables available from Holophane.

4.2 REPLACING THE WINCH CABLE

4.2.1 With the LD ring latched, disconnect the winch cable from the clevis.

4.2.2 Unwind the old winch cable, note the attachment to the winch before disconnecting the cable and then discard the cable.

4.2.3 Attach the new cable obtained from Holophane, in the same manner that the old cable was attached.

4.2.4 While rewinding the winch, wrap as tightly and neatly as possible to avoid crushing of the cable when the load is applied to the winch cable.

4.3 PORTABLE DRIVE MOTOR SHAFT REPLACEMENT

WARNING

Do not attempt to adjust the torque limiting clutch or replace the shear pin. If repairs are necessary, replace damaged equipment with new equipment from Holophane. Failure to follow these warnings may result in injury or death.

If the torque limiter or shear pin need adjustment or repair, return the complete power unit shaft assembly, as shown in Figure 26, to Holophane for authorized factory repair or replacement. Figure 26 gives instructions for its removal. Reversing all steps is necessary for installing the replacement.

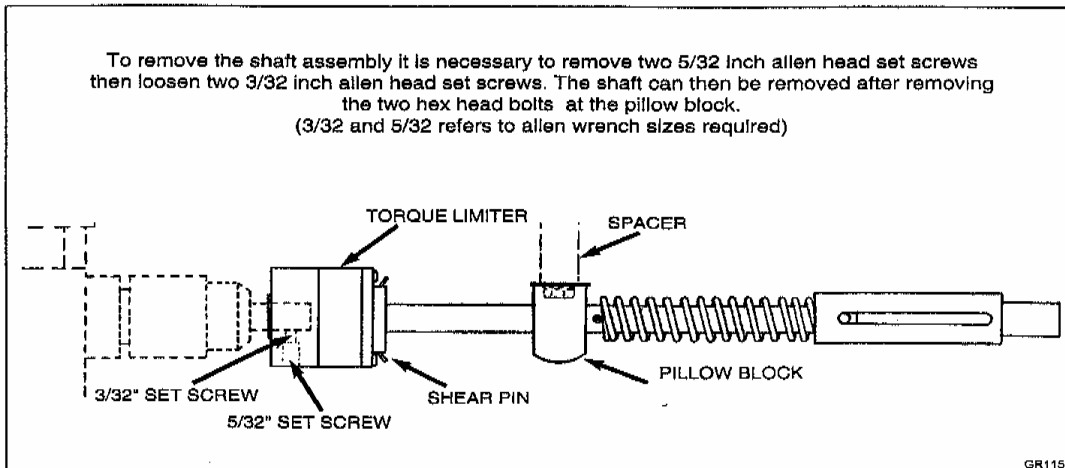

Figure 26